

## Oil Separators and Associated Methods

5

### Technical Field

This invention relates generally to separation science, and relates more particularly to removing a top layer of oil from an aqueous liquid.

10

### Background

When preparing a meat stock, a cook, chef, or homemaker typically boils various animal parts for several hours, and often for more than a whole day, in order to extract all the nutrition from the animal parts, which typically include meat, bones, and fat. At the end of the boiling step, it is universally accepted that the cook, chef, homemaker or preparer must remove the thick layer of oil from the top of the stock. Although it is possible to remove some of the oil layer using a spoon, it is typically impossible to remove all or even a sufficient amount of the oil layer with a spoon. Thus, cookbooks instruct the person to remove the stockpot from the stove, and place the stockpot in a refrigerator for sufficient time to cool the contents of the stockpot so that the oil layer solidifies, after which time the oil is removed as a solid, the stock optionally filtered, and then further cooking using the stock may resume. The present disclosure provides tools by which removal of the oil layer in a stock may be effected in less than five minutes time, thus saving time and energy associated with cooling and re-heating the stock. A tool as provided herein has uses other than in the cooking arts, as detailed herein.

## **Summary of the Invention**

The present disclosure provides separation devices useful for removing a top liquid layer from another liquid. A separation device according to the disclosure  
5 comprises a collection chamber having an outer wall portion, a receiving portion having a cross-sectional surface area, and a discharge portion having a cross-sectional surface area. The cross-sectional surface area of the receiving portion is greater than the cross-sectional surface area of the discharge portion. There is a retention chamber having an inner wall, a bottom end portion, and a top end portion, and the retention chamber is  
10 attached to the outer wall portion of the collection chamber at the bottom end portion of the retention chamber. There is also a handle attached to either the collection chamber or the retention chamber, or both.

15

## Brief Description of the Drawings

In the annexed drawings:

5    **FIG. 1A** shows a perspective view of an oil separator according to one embodiment of the disclosure;

**FIG. 1B** shows a cross-sectional view of a finished meat stock disposed in a stockpot;

10   **FIG. 2** shows a perspective view of the various components of an oil separator according to one embodiment of the disclosure;

**FIG. 3** shows a side perspective view of an oil separator according to one embodiment of the disclosure;

15

**FIG. 4** shows an overhead view of an oil separator according to one embodiment of the disclosure;

20   **FIG. 5** shows a cross-sectional view of a stockpot containing an aqueous layer and an oil layer floating thereon;

**FIG. 6** shows an oil separator according to one embodiment of the disclosure in use;

**FIG. 7** shows an oil separator according to one embodiment of the disclosure after having extracted some of the oil layer shown in **FIG. 5**;

**FIG. 8A** shows a perspective view of a collection chamber useful in providing an oil separator according to one embodiment of the disclosure;

**FIG. 8B** shows an overhead view of a collection chamber useful in providing an oil separator according to one embodiment of the disclosure;

**FIG. 9A** shows a perspective view of a collection chamber useful in providing an oil separator according to one embodiment of the disclosure;

**FIG. 9B** shows an overhead view of a collection chamber useful in providing an oil separator according to one embodiment of the disclosure;

**FIG. 10A** shows a perspective view of a collection chamber useful in providing an oil separator according to one embodiment of the disclosure;

**FIG. 10B** shows an overhead view of a collection chamber useful in providing an oil separator according to one embodiment of the disclosure;

**FIG. 11A** shows a perspective view of a collection chamber useful in providing an oil separator according to one embodiment of the disclosure;

**FIG. 11B** shows an overhead view of a collection chamber useful in providing an oil separator according to one embodiment of the disclosure;

5 **FIG. 12A** shows a perspective view of a collection chamber useful in providing an oil separator according to one embodiment of the disclosure;

**FIG. 12B** shows an overhead view of a collection chamber useful in providing an oil separator according to one embodiment of the disclosure;

10

**FIG. 13A** shows a perspective view of a collection chamber useful in providing an oil separator according to one embodiment of the disclosure;

**FIG. 13B** shows an overhead view of a collection chamber useful in providing an oil

15 separator according to one embodiment of the disclosure;

**FIG. 14A** shows a perspective view of a retention chamber useful in providing an oil separator according to one embodiment of the disclosure;

20 **FIG. 14B** shows a side view of a retention chamber useful in providing an oil separator according to one embodiment of the disclosure;

**FIG. 14C** shows an overhead view of a retention chamber useful in providing an oil separator according to one embodiment of the disclosure;

**FIG. 15A** shows a perspective view of a retention chamber useful in providing an oil separator according to one embodiment of the disclosure;

**FIG. 15B** shows a side view of a retention chamber useful in providing an oil separator according to one embodiment of the disclosure;

**FIG. 15C** shows an overhead view of a retention chamber useful in providing an oil separator according to one embodiment of the disclosure;

**FIG. 16A** shows a perspective view of a retention chamber useful in providing an oil separator according to one embodiment of the disclosure;

**FIG. 16B** shows a side view of a retention chamber useful in providing an oil separator according to one embodiment of the disclosure;

**FIG. 16C** shows an overhead view of a retention chamber useful in providing an oil separator according to one embodiment of the disclosure;

**FIG. 17** shows a perspective view of an oil separator according to one embodiment of the disclosure;

**FIG. 18** shows a perspective view of the underside of a retention chamber 5 according to one embodiment of the disclosure;

**FIG. 19** shows a perspective view of an oil separator according to one alternate  
5 embodiment of the disclosure;

**FIG. 20** shows a perspective view of an oil separator according to another alternate embodiment of the disclosure; and

10 **FIG. 21** shows a perspective view of an oil separator according to another alternate embodiment of the disclosure.

## Detailed Description

Referring to the drawings and initially to **FIG. 1A** there is shown a perspective view of an oil separator **10** according to one embodiment, the specific functions of the various components of which shall be hereinafter described. **FIG. 1B** shows a cross-sectional view of a finished meat stock disposed in a stockpot **27**. The finished meat stock comprises an aqueous layer **29** having a top surface, and an oil layer **31** that has a bottom surface which is coincident with the top surface of the aqueous layer **29**, and a top surface that is exposed to the ambient air and is visible to the cook or chef from the opening **O** at the top of the stockpot **27**. According to the prior art, this oil layer **31** comprises fats and other non-water soluble components of the bones, meat, etc. which were used in the preparation of the stock, and its removal is typically effected by placing the entire stockpot in a refrigerator overnight, until the oil layer **31** solidifies, and is subsequently manually removed from the stockpot **27**.

In **FIG. 2** is shown an oil separator **10** according to one embodiment of the disclosure. An oil separator **10** according to this embodiment comprises a collection chamber **3**, having a receiving portion **13** and a discharge portion **15**. The receiving portion **13** generally comprises a circular opening into which a fluid may flow, and the discharge portion **15** generally comprises a circular opening through which a fluid may flow. It is preferred that the cross-sectional area of the opening at the receiving portion **13** is much greater than the cross sectional area of the opening of the discharge portion **15** (or neck portion **17** when a neck is selected to be present), and in this embodiment it is seen that the collection chamber is conical or funnel-like in shape and appearance. In one

embodiment, the cross-sectional area of the opening at the receiving portion **13** is ten times greater than the cross sectional area of the opening of the discharge portion **15** (or neck portion **17** when a neck is selected to be present). In another embodiment, the cross-sectional area of the opening at the receiving portion **13** is about one hundred times greater than the cross sectional area of the opening of the discharge portion **15** (or neck portion **17** when a neck is selected to be present). In another embodiment, the cross-sectional area of the opening at the receiving portion **13** is about one thousand times greater than the cross sectional area of the opening of the discharge portion **15** (or neck portion **17** when a neck is selected to be present). In many embodiments, the cross-sectional area of the opening at the receiving portion **13** may be greater than the cross sectional area of the opening of the discharge portion **15** (or neck portion **17** when a neck is selected to be present) by any amount between about ten and one thousand times the cross sectional area of the opening of the discharge portion **15** (or neck portion **17** when a neck is selected to be present). In other embodiments, such as where an oil separator according to the disclosure is employed to clean oil spills from bodies of water such as oceans or lakes, the cross-sectional area of the opening at the receiving portion **13** may be greater than the cross sectional area of the opening of the discharge portion **15** (or neck portion **17** when a neck is selected to be present) by any amount greater than one thousand times the cross sectional area of the opening of the discharge portion **15** (or neck portion **17** when a neck is selected to be present). All ranges within any selected two of the various cross sectional areas described above are included within the present disclosure.

In some embodiments, an oil separator **10** according to the disclosure may be interpreted as including a funnel with a neck having a tube attached to its underside, as some of its features. The discharge portion **15** of the collection chamber may be optionally provided with a neck portion **17**, having a first end portion **19** that is attached to the collection chamber **3** at its discharge portion **15**. The neck portion **17** also has a second end portion **21** at which is disposed an opening capable of permitting fluid to flow therethrough, which second end portion may comprise a top surface **23**. Thus, in one embodiment, the collection chamber **3** comprises a conical construct having a coextensive or continuous wall, with a large opening at the receiving portion **13**, and a smaller opening at the discharge portion **15**, and optionally a neck portion **17** thereat. In one embodiment, both of these openings are circular in cross section. In another embodiment, one or more of these openings are oval in cross section. In another embodiment, one or more of these openings are rectangular in cross section. In another embodiment, one or more of these openings are irregular in cross section. However, one of ordinary skill in the art will appreciate after considering the contents of this disclosure that many shapes of openings of these portions of the collection chamber are suitably employed herein.

In this embodiment, there is a retention chamber **5** disposed upon the outer wall **W** of the collection chamber **13** near its discharge portion **15**. In one embodiment, the retention chamber **5** is tubular and is circular in cross section. In another embodiment, the retention chamber **5** is tubular and is oval in cross section. In another embodiment, the retention chamber **5** is tubular and is rectangular in cross section. In another embodiment, the retention chamber **5** is tubular and is irregular in cross section.

However, one of ordinary skill in the art will appreciate after considering the contents of this disclosure that many shapes of cross sections of the retention chamber are suitably employed herein. The retention chamber **5** has a bottom end portion **7** and a top end portion **9**, which may comprise a top surface **11**. It is preferred that the bottom end portion **9** forms a seal with the outer wall **W** of the collection chamber, coextensively therewith, so as to define a retained volume **25** disposed within the retention chamber **5**. The retained volume **25** is a volume that is defined by the inner wall **37** of the retention chamber **5** and the portion of the collection chamber **3** which is disposed within the retention chamber, and also by the wall of the neck portion **17** when selected to be present. The amount of liquid substance which the retained volume **25** is capable of holding, when the oil separator **10** is oriented as shown in **FIG. 2**, is controlled by the location of the discharge portion **15** within the retention chamber **5** (or location of the second end **21** of the neck portion **17**, when present), the geometry of the outer wall **W** of the collection chamber, and the geometry of the inner wall **37** of the retention chamber **5**.

15 In one embodiment, the collection chamber **3** and retention chamber **5** are both made from polymeric materials (homopolymers or copolymers), which includes without limitations those polymers such as polyolefins, PET polymers, acrylates, urethanes, polycarbonates, silicones, halogenated polymers such as PVC, CPVC, ethylene vinyl acetate copolymers, and includes all polymers that are known in the art as being approved for food use etc. In one embodiment, the collection chamber **3** and retention chamber **5** are both made from polycarbonate plastic. In another embodiment, the collection chamber **3** and retention chamber **5** are both made from a metal, such as copper. In another embodiment, the collection chamber **3** and retention chamber **5** are both made

from a metallic alloy, including without limitation known stainless steel alloys.

Electroplated metals and electroplated alloys are also suitable, including without limitation, tin-plated copper. In another embodiment, the collection chamber **3** and retention chamber **5** are both made from a glass, and when a glass is selected, it is

5 preferable that the glass be tempered, such as a PYREX® glass. In one preferred embodiment, the collection chamber **3** and retention chamber **5** are both part of the same singular construct, such as when made by an injection or blow molding process for the case where these elements of the oil separator **10** are selected to be polymers. In an alternate embodiment, the collection chamber **3** and retention chamber **5** are both made

10 separately and are attached to one another using conventional fastening means, such as adhesives, glues, thermowelding, screws, rivets, or the like, with the proviso being that a gasket is employed at the interface of the collection chamber **3** and retention chamber **5** to ensure a good seal therebetween and to prevent leakage of any fluid out of the retained volume **25**. Such gasket materials are known in the art and may include foam materials,

15 rubbers, various polymers or other known gasket materials, including liquid gasket materials which cure or are cured after application. In some embodiments when an adhesive is employed, the adhesive itself may function as a gasket material. All known adhesives useful for joining the above-mentioned materials of construction to one another may be employed, and the present disclosure also includes an oil separator **10** wherein

20 the collection chamber **3** and retention chamber **5** are each comprised of different materials from one another.

In one embodiment the retention chamber **5** includes a pouring spout **35** disposed at its top surface **11**. The pouring spout **35** facilitates the pouring out of oil

which is caused to be collected in the retention volume **25** during normal use of any oil separator **10** provided by this disclosure. The pouring spout **35** in one embodiment comprises a notch disposed at the top surface **11** of the retention chamber **5**. In another embodiment the pouring spout **35** is a molded-in or cast-in feature, such as the type of pouring spouts commonly present on PYREX® measuring cups designed for home cooking use (as shown in **FIG. 17**). Further alternate pouring spouts may be used as well. The location of the pouring spout **35** may be at any location on or within about a couple centimeters from the top surface **11** of the retention chamber **5**.

In one embodiment, the retention chamber **5** is graduated, as shown in **FIG. 3**. These graduations may be cast-in, when the retention chamber **5** is selected to be comprised of a polymeric material, such as a clear polycarbonate. In alternative embodiments the graduations are printed or silkscreened onto the exterior of retention chamber **5**. In further alternative embodiments the graduations are pressed, embossed, or crimped into the retention chamber **5**, such as when the retention chamber **5** is selected to be comprised of aluminum, tin, a stainless steel or other metal, akin to graduations employed in the art in the case of measuring cups comprising aluminum, which have graduations pressed-in.

**FIG. 3** shows the side perspective view of an oil separator **10** according to that of the embodiment of **FIG. 2**. In this **FIG. 2** are shown the respective locations of the collection chamber **3**, the receiving portion of the collection chamber **3**, the retention chamber **5**, the bottom end **7** of the retention chamber **5**, optional neck **17**, the top end **9** of the retention chamber **5**, and the retained volume **25**. Also shown is the angle alpha ( $\alpha$ ), which is the angle the wall of the collection chamber **3** makes with the horizontal

defined by the receiving portion **13** of the collection chamber **3** in this side perspective view. The angle alpha ( $\alpha$ ) may take on any value in degrees in the range of between about 10 degrees to about 80 degrees in such a side perspective view of this one embodiment of an oil separator **10**.

5            Also shown in **FIG. 3** are the dimensions **h1**, **h2**, **h3**, and **h4**. The dimension **h1** is the distance from the bottom end **7** (in some embodiments the "bottom end" is measured from the inside of the retention chamber **5**, in others, the "bottom end" is measured on the outside of the retention chamber **5**) of the retention chamber **5** to the discharge portion **15** of the collection chamber **3**, and the dimension **h2** is the distance  
10 from the bottom end **7** (in some embodiments the "bottom end" is measured from the inside of the retention chamber **5**, in others, the "bottom end" is measured on the outside of the retention chamber **5**) of the retention chamber **5** to the top surface **23** of the neck **17**, when present. The dimension **h3** (length dimension of retention chamber) is the distance from the bottom end **7** (in some embodiments the "bottom end" is measured  
15 from the inside of the retention chamber **5**, in others, the "bottom end" is measured on the outside of the retention chamber **5**) of the retention chamber **5** to the top end **9** of the retention chamber **5**, and the dimension **h4** is the distance from the receiving portion **13** of the collection chamber **3** to the bottom end **7** of the retention chamber **5**. In one embodiment when a neck portion **17** is selected to be present, the sum of **h4** + **h2** is less  
20 than the sum of **h3** + **h4**. In another embodiment when a neck portion **17** is selected to not be present, the sum of **h4** + **h1** is less than the sum of **h3** + **h4**. The cases where the "bottom end" **7** is measured from the inside or outside of the retention chamber **5** are each applicable to all embodiments described herein. **L** is the length of the neck portion **17**.

In one embodiment, the distance **h1** is about 10 % of the distance **h3**. In another embodiment, the distance **h1** is about 20% of the distance **h3**. In another embodiment, the distance **h1** is about 30% of the distance **h3**. In another embodiment, the distance **h1** is about 40% of the distance **h3**. In another embodiment, the distance **h1** is about 50% of the distance **h3**. In another embodiment, the distance **h1** is about 60% of the distance **h3**. In another embodiment, the distance **h1** is about 70% of the distance **h3**. In another embodiment, the distance **h1** is about 80% of the distance **h3**. In another embodiment, the distance **h1** is about 90% of the distance **h3**. In another embodiment, the distance **h1** is about 95% of the distance **h3**.

10 In one embodiment, the distance **h2** is about 10 % of the distance **h3**. In another embodiment, the distance **h2** is about 20% of the distance **h3**. In another embodiment, the distance **h2** is about 30% of the distance **h3**. In another embodiment, the distance **h2** is about 40% of the distance **h3**. In another embodiment, the distance **h2** is about 50% of the distance **h3**. In another embodiment, the distance **h2** is about 60% of the distance **h3**. In another embodiment, the distance **h2** is about 70% of the distance **h3**. In another embodiment, the distance **h2** is about 80% of the distance **h3**. In another embodiment, the distance **h2** is about 90% of the distance **h3**. In another embodiment, the distance **h2** is about 95% of the distance **h3**.

20 In one embodiment, the distance **h3** is about 20% of the distance **h4**. In another embodiment, the distance **h3** is about 30% of the distance **h4**. In another embodiment, the distance **h3** is about 40% of the distance **h4**. In another embodiment, the distance **h3** is about 60% of the distance **h4**. In another embodiment, the distance **h3** is about 70% of the distance **h4**. In another embodiment, the distance **h3** is about 80% of the distance **h4**.

In one embodiment, the distance **h3** is about the same as the distance **h4**. In another embodiment, the distance **h3** is about 120% of the distance **h4**. In another embodiment, the distance **h3** is about 130% of the distance **h4**. In another embodiment, the distance **h3** is about 140% of the distance **h4**. In another embodiment, the distance **h3** is about 150% of the distance **h4**. In another embodiment, the distance **h3** is about 160% of the distance **h4**. In another embodiment, the distance **h3** is about 170% of the distance **h4**. In another embodiment, the distance **h3** is about 180% of the distance **h4**. In another embodiment, the distance **h3** is about twice the distance **h4**. In another embodiment, the distance **h3** is any amount greater than twice the distance **h4**.

10           The above-described embodiments detailing the various relative dimensions of the components of an oil separator **10** according to this disclosure are applicable to all embodiments, including all described shapes and configurations of the collection chamber **3**, retention chamber **5**, and neck portion **17** when selected to be present.

15           In **FIG. 4** is shown an overhead view of an oil separator **10** according to one embodiment. **FIG. 4** shows the respective locations of the collection chamber **3**, retention chamber **5**, top surface **11** of retention chamber **5**, neck portion **17**, top surface **23** of neck portion **17**, and the second end **21** of the neck portion **17**, which functions as a discharge portion of the collection chamber **3** when such neck portion **17** is present. Also shown is the location of the retained volume **25**.

20           In **FIG. 5** is shown a cross sectional view of a stockpot **27** containing an aqueous layer **29** and an oil layer **31** floating thereon. An oil separator **10** is shown in position just prior to its use in removing the top oil layer **31** from the aqueous layer **29** while the contents of the stockpot **27** are still hot, without the need for refrigerating the

contents of the stockpot to cause solidification of the oil layer **31** prior to its substantial removal from the stockpot **27**. During use, the oil separator **10** is provided, placed over the top of the oil layer **31** as shown, and then lowered into the stockpot **27** in the direction of the arrows, as shown in **FIG. 5**, until the discharge portion **15** of the collection chamber **3** is disposed at a location within the oil layer **31**, as shown in **FIG. 6**. In going from the position shown in **FIG. 5**, to the position shown in **FIG. 6**, the receiving portion **13** of the collection chamber **3** of an oil separator **10** according to the disclosure first contacts the top surface of the oil layer **31**. As the oil separator is being lowered into the stockpot **27**, that portion of the oil layer **31** which is disposed beneath the receiving portion **13** of the collection chamber **3** is caused to be pushed upwards, especially when and after the receiving portion **13** of the collection chamber **3** contacts the aqueous layer **29**, which forces the oil layer **31** in an upward direction, within the confines of the receiving chamber towards the discharge portion **15** of the collection chamber **3**. Once the oil separator **10** is disposed as is shown in **FIG. 6**, the oil that was captured by the receiving portion **13** has been forced upward and out of the discharge portion **15** of the collection chamber **3**, as shown by the arrows in **FIG. 6**, whereupon the oil so collected enters the retained volume **25** and is precluded from re-entering the stockpot by virtue of the design of the oil separator **10** and its use as herein described. With the maximum amount of oil that is removable with one extraction step as described above being determined by the dimension **h1** or **h2** of **FIG.3**, depending on whether or not a neck portion **17** is selected to be present. Following submersion of the oil separator **10** as shown in **FIG. 6**, the oil separator **10** is removed from the stockpot **27** as shown by the arrows in **FIG. 7**, and the collected oil **33** is shown disposed within the retained volume

25 (not labeled). After such an operation shown in **FIGS. 5, 6, 7**, the oil layer **31** in stockpot **27** is thinner. The collected oil **33** is dumped out of the oil separator **10** into a separate containment vessel, or discarded, and the operation shown in **FIGS. 5, 6, 7** is repeated, collecting and removing more of the oil layer **31** until it is eventually gone, 5 which typically requires 4 – 6 such operations as shown in **FIGS. 5, 6, 7** and requires about three minutes time. Thus, the present disclosure provides cooks, chefs and others preparing meat stocks with devices and methods for saving a tremendous amount of time. Additionally, cooling a large volume of stock requires refrigerator space and the use of energy to cool the stock to solidify the oil layer **31** according to currently-accepted 10 methods, which the present disclosure changes from being state-of-the-art, to becoming prior art method. According to the prior art method of refrigerating the stock to solidify the oil layer **31**, energy was necessary to cool the contents of the stockpot **27**. However, in addition, when the cook, chef, or other desired to then use the stock in preparing a finished meal, entrée, or other item, the contents of the stockpot **27** had to be again re- 15 heated, typically to boiling. Thus, the present disclosure saves: 1) energy of cooling the contents of the stockpot; 2) energy of re-heating the contents of the stockpot; and 3) about eight hours or more of time. Thus, cooks, chefs, and others will be enamored by the devices and methods provided by the present disclosure.

From the foregoing it is now readily understood that an oil-separator according 20 to this disclosure may comprise collection chambers **3** and retention chambers **5** having various geometries while retaining the function as herein described. In addition, any embodiment may or may not include a neck portion **17**, which is generally tubular-shaped with a circular, oval, rectangular or any other cross-section. In a preferred embodiment,

the neck portion **17** is tubular (cylindrical) and has parallel walls as shown in **FIG. 2**. In other embodiments the walls of the neck portion **17** are non-parallel, including convex and concave as viewed from a side perspective.

**FIG. 8A** and **8B** show a perspective view and an overhead view, respectively, of a collection chamber **3** according to one embodiment of the invention, in which the collection chamber **3** is conical and circular as viewed from above.

**FIG. 9A** and **9B** show a perspective view and an overhead view, respectively, of a collection chamber **3** according to one embodiment of the invention, in which the collection chamber **3** is conical and oval as viewed from above.

**FIG. 10A** and **10B** show a perspective view and an overhead view, respectively, of a collection chamber **3** according to one embodiment of the invention, in which the collection chamber **3** is conical and oval as viewed from above. In this embodiment, the wall **W** of the collection chamber **3** is seen to be convex, as opposed to linear in some other embodiments. The wall **W** of the collection chamber **3** may also be concave. In addition, the embodiment of **FIG. 10A** comprises a skirt portion **S** attached to the bottom portion of the collection chamber **3** wherein the skirt portion includes walls which feature a discontinuity with respect to the remainder of the walls of the collection chamber **3**. The wall of a skirt as disclosed herein may be linear, concave, or convex as viewed from a side perspective. The skirt **S** may in any embodiment have a height **H1** that is any amount between about 5% and 95% of the total height **H2** of a collection chamber **3** according to the disclosure, whether **H2** is measured at the discharge portion **15** or the top surface of the neck portion **17**, when a neck portion is selected to be present.

**FIG. 11A** and **11B** show a perspective view and an overhead view, respectively, of a collection chamber **3** according to one embodiment of the invention, in which the collection chamber **3** is generally conical and circular as viewed from above. The wall **W** and receiving portion **13** of the collection chamber in **FIG. 13A** are seen to be convex, however, this disclosure also provides collection chambers having linear and concave walls **W** and receiving portions **13**.

**FIG. 12A** and **12B** show a perspective view and an overhead view, respectively, of a collection chamber **3** according to one embodiment of the invention, in which the collection chamber **3** is pyramidal and rectangular as viewed from above. Within this disclosure, the word "rectangular" also includes square, as such term is applied in the art of geometry to include squares.

**FIG. 13A** and **13B** show a perspective view and an overhead view, respectively, of a collection chamber **3** according to one embodiment of the invention, in which the collection chamber **3** is pyramidal and rectangular as viewed from above. In this embodiment, the wall **W** of the collection chamber **3** is seen to be convex, as opposed to linear in some other embodiments. The wall **W** of the collection chamber **3** may also be concave. In addition, the embodiment of **FIG. 13A** comprises a skirt portion **S** attached to the bottom portion of the collection chamber **3** wherein the skirt portion includes walls which feature a discontinuity with the remainder of the walls of the collection chamber **3**. The wall of a skirt as disclosed herein may be linear, concave, or convex as viewed from a side perspective.

In **FIG. 14A, 14B, 14C** are shown a perspective, side, and overhead view of a retention chamber **5** useful in accordance with this disclosure, wherein the retention

chamber **5** is tubular in configuration and circular as viewed from above. The bottom end **7** in each of the embodiments in **FIGS. 14A, 14B, 14C** is linear; however, the present disclosure also provides a bottom end **7** having concave and convex bottom ends.

In **FIG. 15A, 15B, 15C** are shown a perspective, side, and overhead view of a retention chamber **5** useful in accordance with this disclosure, wherein the retention chamber **5** is tubular in configuration and rectangular as viewed from above. The bottom end **7** in each of the embodiments in **FIGS. 15A, 15B, 15C** is concave; however, the present disclosure also provides a bottom end **7** having linear and convex bottom ends.

In **FIG. 16A, 16B, 16C** are shown a perspective, side, and overhead view of a retention chamber **5** useful in accordance with this disclosure, wherein the retention chamber **5** is tubular in configuration and oval as viewed from above. The bottom end **7** in each of the embodiments in **FIGS. 16A, 16B, 16C** is linear; however, the present disclosure also provides a bottom end **7** having concave and convex bottom ends.

**FIG. 17** shows an oil separator **10** according to an alternate embodiment of the disclosure, showing the respective locations of the collection chamber **3**, retention chamber **5**, optional neck portion **17**, and spout **35**. The spout **35** may be disposed at any location on or near the top surface **11** of the retention chamber **5**. There are also handle supports **39**, which are attached to the retention chamber **5** by conventional means, which may include without limitation, the handle support **39** being molded singularly with the same piece used for the retention chamber **5**. In an alternate embodiment, the handle supports comprise shafts which are disposed through the wall of the retention chamber **5** and are affixed thereto by the means of screws which may be threaded into the ends of such shafts, fastening being accomplished by the larger diameter of the head of such

screws relative to the holes in the retention chamber through which the shafts are disposed. The handle support **39** may be rigidly or pivotally connected to the retention chamber **5**, using any means known in the art for attaching a handle support to a tubular construct such as is a retention chamber **5** herein. The handle **41** in one embodiment is comprised of wood and has a hole disposed through its center along its length through which the handle support **39** passes. In an alternate embodiment, the handle **41** is of singular construction with the handle supports, i.e., one single molded piece comprises both the handle **41** and the support **39**. In one embodiment, the collection chamber **3**, retention chamber **5**, handle support **39** and handle **41** comprise a single article of manufacture, being made from an injection molding process.

**FIG. 18** shows a perspective view of the underside of a retention chamber **5** useful in accordance with this disclosure, wherein the bottom portion **7** comprises a bevel **43**. The bevel **43** is preferably contoured to match the angle or contour of the collection chamber **3** to which it is attached, for those embodiments when the collection chamber **3** and retention chamber **5** are not of singular or unitary construction. The angle or contour of the bevel **43** thus desirably matches the contour or curvature of the wall of the collection chamber **3** to which it is attached in such embodiments.

**FIG. 19** shows an oil separator **10** according to one preferred embodiment of the present disclosure, showing the respective locations of the collection chamber **3** having a receiving portion **13**, and the graduated retention chamber **5** attached thereto, which features a spout **35** and a handle **41** attached to the retention chamber **5** by means of a handle support **39**, which may or may not be integral with the handle **41**. In this embodiment, the spout **35** is disposed on the top surface **11** of the retention chamber **5** at

a location which is about 90 degrees with respect to the attachment of the handle **41** to the retention chamber, as viewed from above. This embodiment is especially favorable because it enables a user to separate an oil layer from a warm or hot stock without any need for contacting the user's hands or fingers with the stock, and thus precludes the possibility of burning one's hands. In one alternative form of this embodiment, the handle **41** is comprised of wood and rides on the support **39**, the support **39** being disposed through a hole down the middle of the handle **41**. Methods of attaching a handle to a tubular structure such as the retention chamber **5** are well-known in the art, including without limitation the means which have been employed for attaching handles to other kitchen wares, including pots and pans, which can include conventional fastening means such as an attendant plate which is riveted thereto. Alternatively, the support **39** may comprise a tubular construct having a threaded hole disposed at its end, and the retention chamber is drilled at a desired location, and a fastener such as a screw having threads complementary to the threaded hole in the tubular construct comprising the support **39** may be disposed through the hole in the retention chamber **5** from the direction of the inner wall **37** of the retention chamber **5**, through the wall of the retention chamber, and into the threaded hole of the support **39**. In another alternate embodiment, the support **39**, handle **41**, and retention chamber **5** are of unitary construction, being made by an injection molding process, or by casting when an oil separator **10** according to this disclosure is selected to be comprised of die-cast zinc, as may be the case with any embodiment herein.

**FIG. 20** shows an oil separator **10** according to another embodiment of the present disclosure, showing the respective locations of the collection chamber **3** having a

receiving portion **13**, and the graduated retention chamber **5** attached thereto, which features a spout **35** and a handle **41** attached to the retention chamber **5** by means of a handle support **39**, which may or may not be integral with the handle **41**. In this embodiment, the spout **35** is disposed on the top surface **11** of the retention chamber **5** at a location which is about 90 degrees with respect to the attachment of the handle **41** to the retention chamber, as viewed from above. This embodiment includes a longer neck portion **17** than the device shown in **FIG. 19** and thus has a retention chamber **5** which has a greater oil-storing capacity than that of the device shown in **FIG. 19**. These embodiments having handles attached to the retention chamber **5** are convenient and are also desirable since such a feature enables a user to separate an oil layer from a warm or hot stock without any need for contacting the user's hands or fingers with the stock, and thus dramatically reduces the probability for one to burn their hands during a oil removal procedure. As with all other embodiments described herein, these embodiments may comprise features described elsewhere herein. This is seen in regards to the oil separator shown in **FIG. 1A**, wherein the handle support **39** has an offset, which beneficially enables a user's hand grasping the handle **41** to be at a different vertical elevation relative to other embodiments, and is illustrative of the versatility of the present disclosure, for, various handles having any shape, configuration, length and point of attachment to either the neck portion **17**, the collection chamber **3**, or retention chamber **5**. The use of various handles provides devices constructed after reading this disclosure great versatility in use. The present disclosure provides handles which are several decimeters long, for employment in chemical manufacturing, the brewing arts, fermentations, and any other application where a person desires to remove a floating layer from any other lower layer

of material. Thus, while an oil separator **10** has been described herein as being useful for removing the oil layer from cooked meat stocks, its use is by no means limited thereto in any way. A separator **10** according to this disclosure may be comprised of cast iron, and is thus useful in skimming the dross from molten metals used in foundry work. It is  
5 useful in skimming froth in beer and winemaking to provide enhanced flavor qualities. It is useful in skimming froth layers from layers formed during processes employed by the pharmaceutical manufacturing arts during various preparations. It is useful in providing a sample of the top layer (for compositional analysis) in any chemical manufacturing process that utilizes separation as a means of extraction or purification, to ensure  
10 compliance of a process with theoretical distribution coefficients. For ease of transportation, cleaning, and use, the handle **41** or handle support **39** may be detachable, using any means known in the art for providing detachable handling means to various wares. While the handle **41** has been shown as being attached to the retention chamber **5**, the present disclosure also provides embodiments wherein the handle **41** is attached to the  
15 collection chamber **3**, using means of attachment of handles to wares which are known to those skilled in various arts of wares comprising handles attached thereto. One such embodiment is shown in perspective view in **FIG. 21**, wherein the handle support **39** may have any length between a few centimeters when used in a kitchen, to a few meters long, when a separator **10** according to the disclosure is employed for sampling a froth, oil  
20 layer, etc. in a chemical process or storage tank.

In a general sense, it is desirable that the cross sectional area of the receiving portion **13** of the collection chamber **3** is greater than the cross sectional area of the discharge portion **15** of the collection chamber (or the opening at the top surface **23** of the

neck portion **17**, when a neck portion is selected to be present). Such provision enables concentration of the oil layer and forces it upward in the collection chamber **3** to facilitate its discharge through the discharge portion **15** as downward pressure is exerted by the user on the handle **41** during an extraction process. An extraction of an oil layer as  
5 taught herein may be undertaken using an oil separator **10** according to any embodiment provided herein.

Consideration must be given to the fact that although this disclosure describes and discloses in relation to certain preferred embodiments, obvious equivalent modifications and alterations thereof will become apparent to one of ordinary skill in this art upon  
10 reading and understanding this specification and the claims appended hereto. This includes subject matter defined by any combination of any one of the various claims appended hereto with any one or more of the remaining claims, including the incorporation of the features and/or limitations of any dependent claim, singly or in combination with features and/or limitations of any one or more of the other dependent  
15 claims, with features and/or limitations of any one or more of the independent claims, with the remaining dependent claims in their original text being read and applied to any independent claim(s) so modified. This also includes combination of the features and/or limitations of one or more of the independent claims with features and/or limitations of other independent claims to arrive at a modified independent claim, with the remaining  
20 dependent claims in their original text being read and applied to any independent claim so modified. Accordingly, the present disclosure is intended to cover all such modifications and alterations, and is limited only by the scope of the claims which follow and the disclosure herein.

I claim:

1) A separation device useful for removing a top liquid layer from another liquid, which comprises:

5           a) a collection chamber having an outer wall portion, a receiving portion having a cross-sectional surface area, and a discharge portion having a cross-sectional surface area, wherein said cross-sectional surface area of said receiving portion is greater than said cross-sectional surface area of said discharge portion;

          b) a retention chamber having a length dimension, an inner wall, a bottom end  
10       portion, and a top end portion,

said retention chamber being attached to said outer wall portion of said collection chamber at said bottom end portion of said retention chamber, thus defining a retained volume; and

          c) a handle attached to a chamber selected from the group consisting of: said  
15       collection chamber and said retention chamber.

2) A separation device according to claim 1 wherein said handle is attached to said retention chamber.

20       3) A separation device according to claim 1 wherein said handle is attached to said collection chamber.

- 4) A separation device according to claim 1 further comprising a pouring spout disposed on said retention chamber at said top end portion of said retention chamber.
- 5) A separation device according to claim 4, wherein said pouring spout is disposed on said retention chamber at a location which is at about 90 degrees with respect to the  
5 location at which said handle is attached to said separation device, as viewed from above.
- 6) A separation device according to claim 1 wherein said retention chamber is graduated.
- 7) A separation device according to claim 1 wherein said retention chamber is made from  
10 a translucent polymeric material.
- 8) A separation device according to claim 1 wherein said retention chamber and said collection chamber are of unitary construction.
- 15 9) A separation device according to claim 8 wherein said inner wall of said retention chamber is smooth.
- 10) A separation device according to claim 1 wherein said retention chamber and said collection chamber are of unitary construction, comprising a single injection-molded  
20 piece.
- 11) A separation device according to claim 10 wherein said inner wall of said retention chamber is smooth.

12) A separation device according to claim 1 further comprising: d) a tubular neck  
portion having a first end portion and a second end portion, wherein said neck portion is  
attached to said discharge portion of said collection chamber at said first end portion of  
5 said neck portion.

13) A separation device according to claim 12 wherein the length of said tubular neck  
portion is any length between about 5 % and 95 % of the length dimension of said  
retention chamber.  
10

14) A separation device according to claim 1 wherein said retained volume has any  
capacity between about 10 milliliters and one liter

15) A separation device according to claim 1 wherein said retained volume has any  
15 capacity between about 20 milliliters and 500 milliliters.

16) A separation device according to claim 1 wherein said retained volume has any  
capacity between about 20 milliliters and 200 milliliters.

20

17) A process for removing a top layer material from atop another layer which comprises the steps of:

A) providing a separation device which comprises:

5 a) a collection chamber having an outer wall portion, a receiving portion having a cross-sectional surface area, and a discharge portion having a cross-sectional surface area, wherein said cross-sectional surface area of said receiving portion is greater than said cross-sectional surface area of said discharge portion;

10 b) a retention chamber having a length dimension, an inner wall, a bottom end portion, and a top end portion,

said retention chamber being attached to said outer wall portion of said collection chamber at said bottom end portion of said retention chamber, thus defining a retained volume; and

15 c) a handle attached to a chamber selected from the group consisting of: said collection chamber and said retention chamber;

B) providing a liquid that comprises a top layer material disposed atop another layer of material;

20 C) lowering the receiving portion of said separation device onto said top layer material sufficiently to cause a portion of said top layer material to be forced through said discharge portion of said collection chamber and into said retained volume;

D) withdrawing said separation device from said liquid; and

E) pouring said top layer material that is contained in said retained volume out of said retained volume.

18) A process according to claim 17, which further comprises: repeating steps C) through E) until a desired amount of said top layer material has been removed from said other layer.

5 19) A process according to claim 17 wherein said top layer material is poured into a separate storage receptacle.

20) A process according to claim 17 wherein said top layer material comprise a material that is selected from the group consisting of: vegetable oils, animal fat, crude oil, organic  
10 solvents, and fermentation froths.

## **ABSTRACT OF THE DISCLOSURE**

Provided herein are devices and methods for removing layers of liquid material which float atop other layers of liquid material. In preferred embodiments, a device as  
5 provided herein is useful for removing a fat layer from a beef or chicken stock that is prepared in a stockpot, without the need for refrigeration of the stock and solidification of the fat layer prior to its removal, thus saving energy costs associated with cooling and re-heating the liquid, as well as the time involved which typically amounts to several hours. A separation device as provided herein may be considered as an oil separator, and in use  
10 is typically lowered onto the fat layer, which causes the fat to be forced upwardly to be collected in a retained volume on board the separation device. The collected fat is poured off into a separate vessel for collection, and the process is repeated until substantially all of the fat is removed, typically requiring only 4 -5 quick extractions, and less than five minutes time.

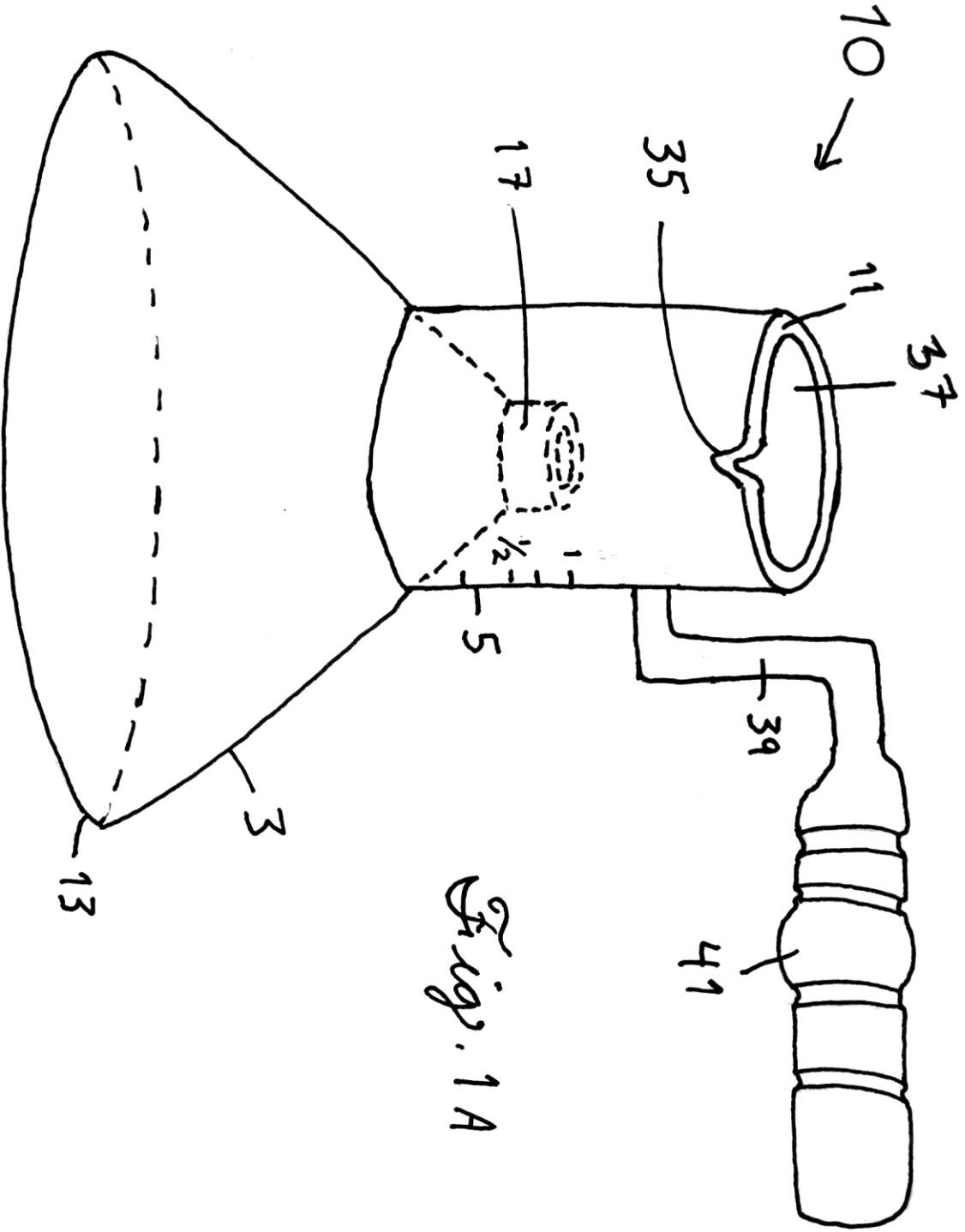
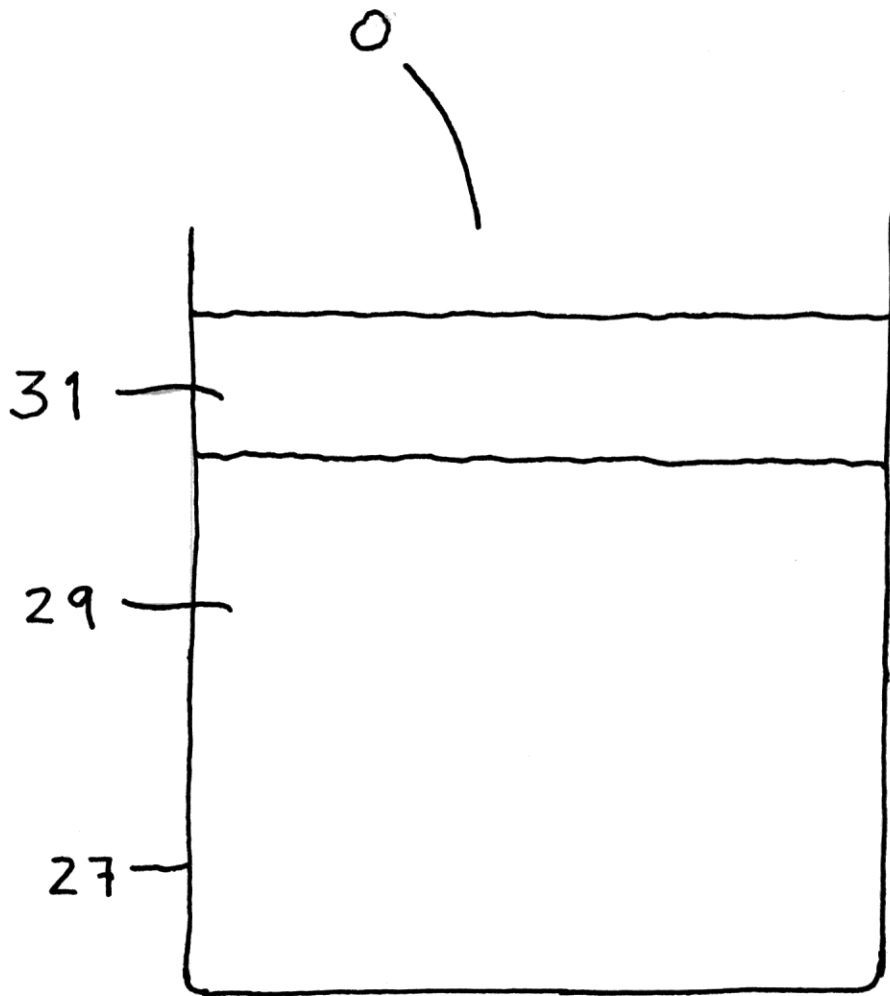

Fig. 1A



*Fig. 1B (PRIOR ART)*



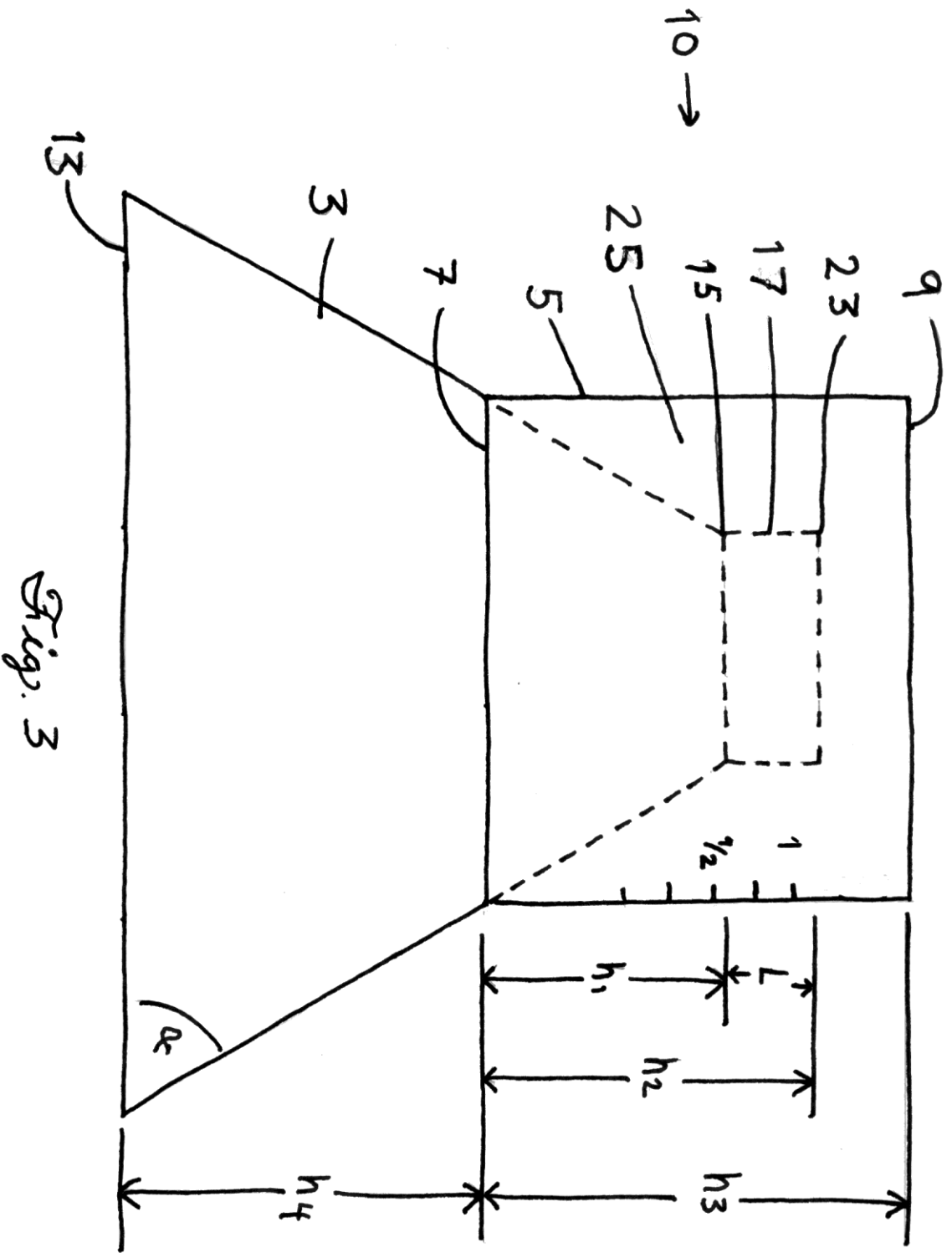

Fig. 3

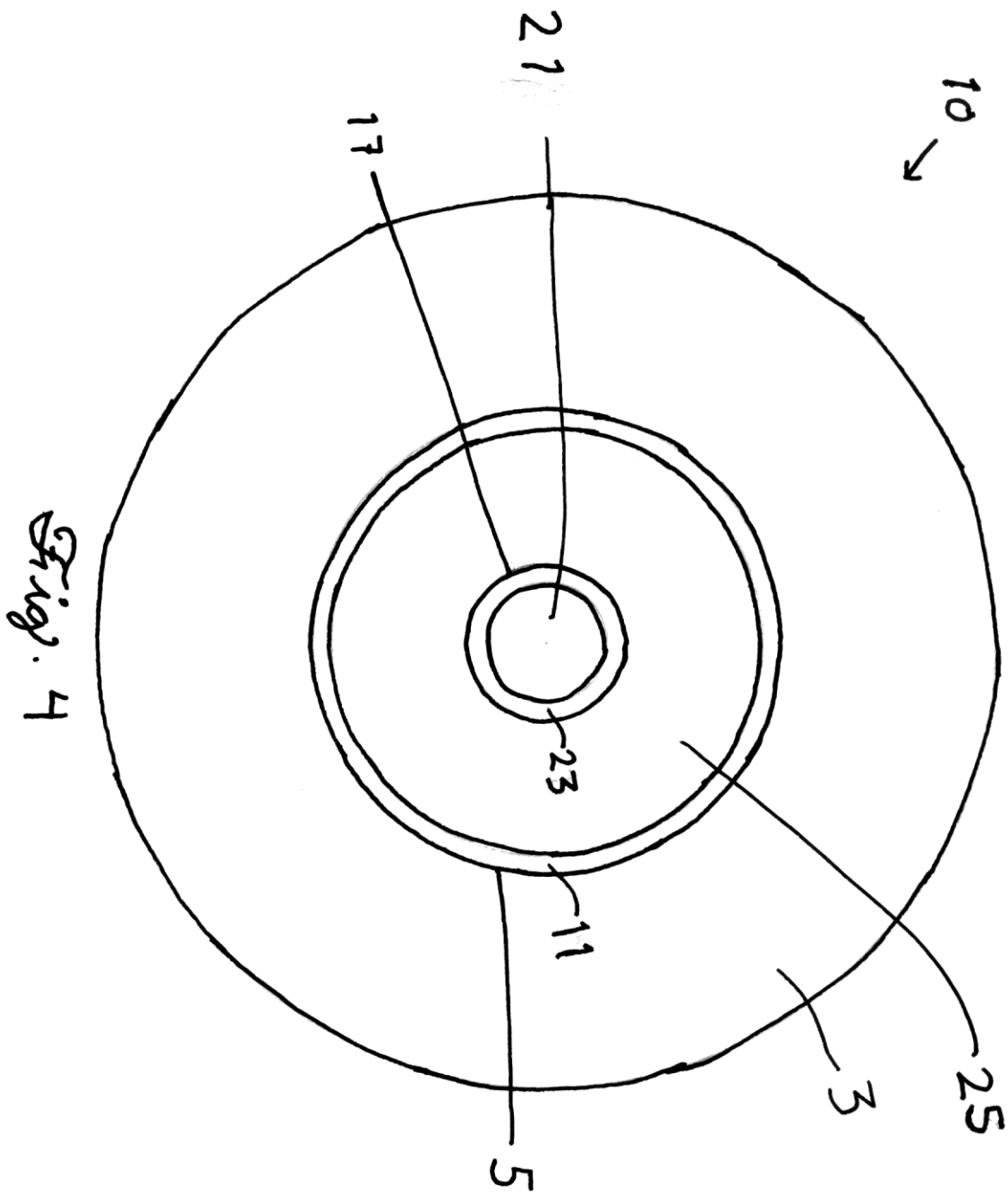
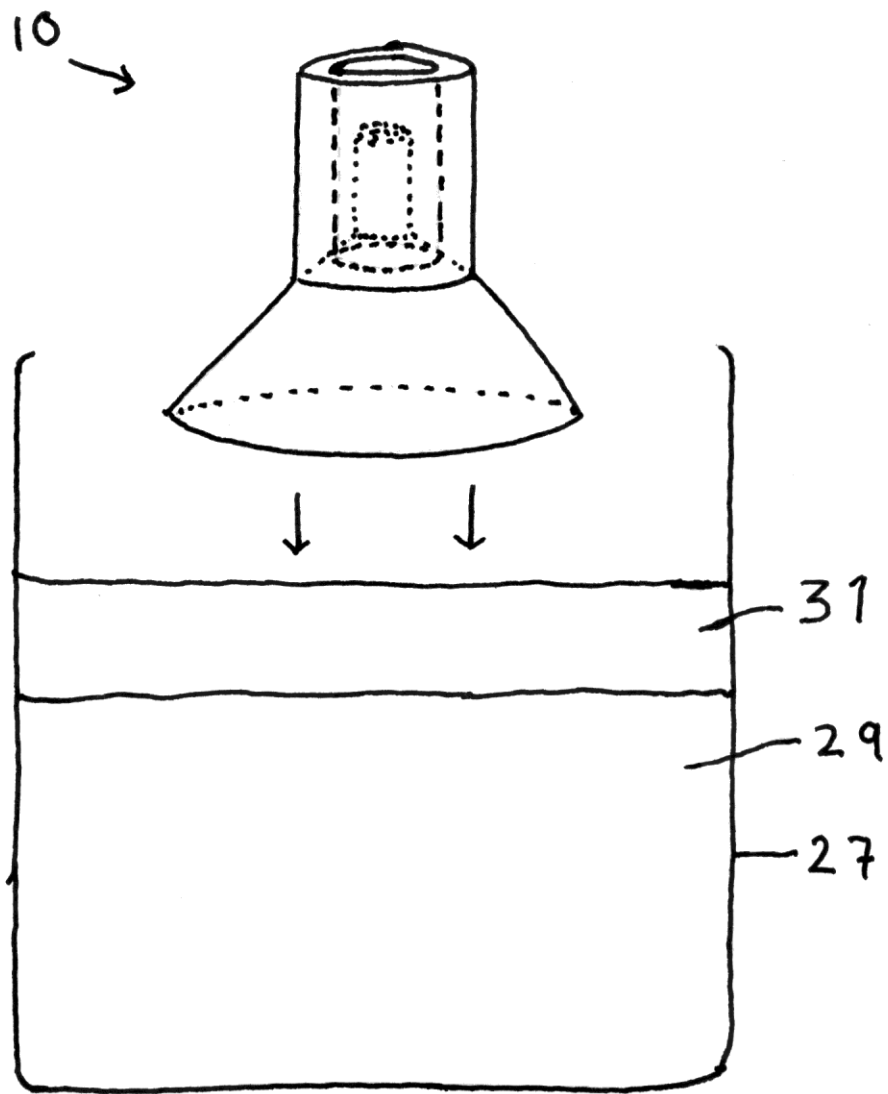

Fig. 4



*Fig. 5*

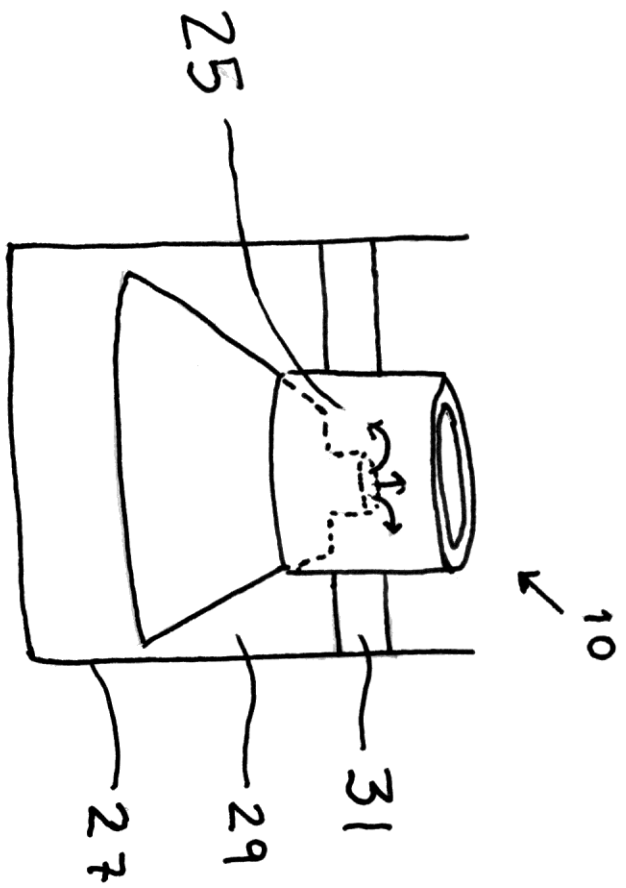

Fig. 6

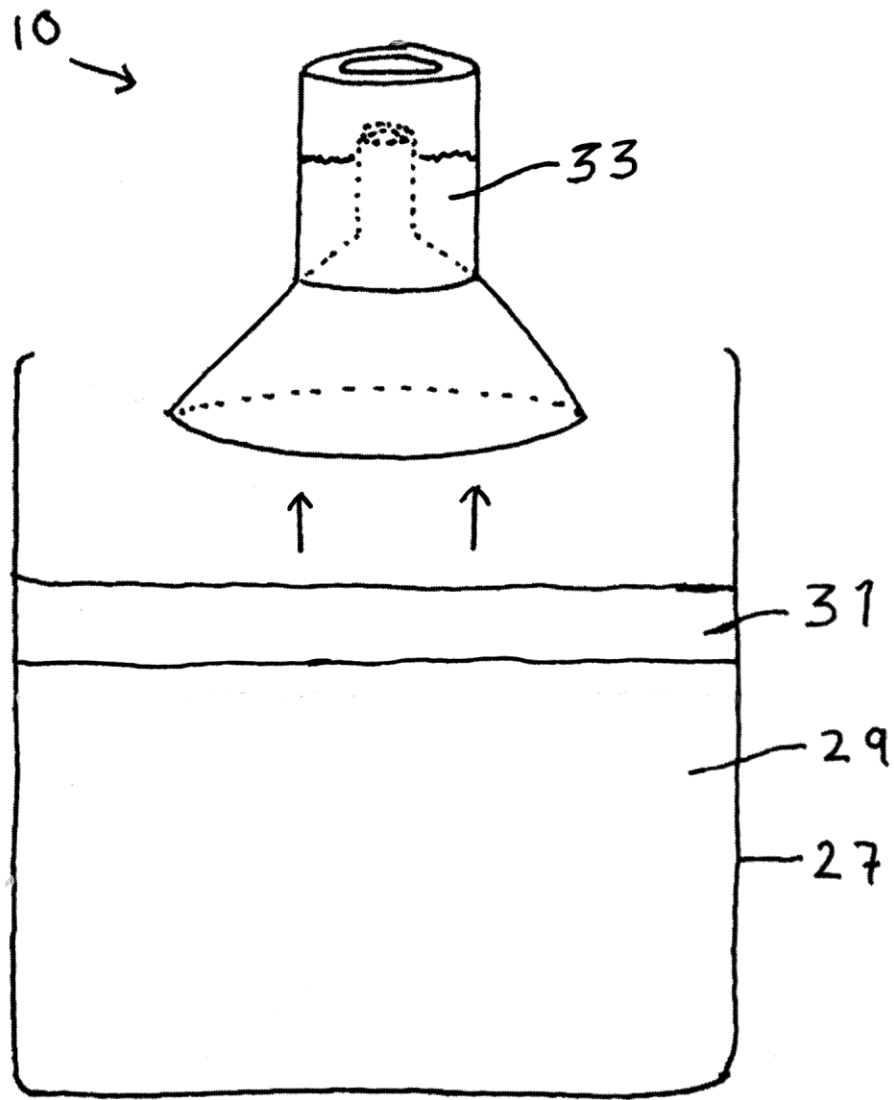

Fig. 7

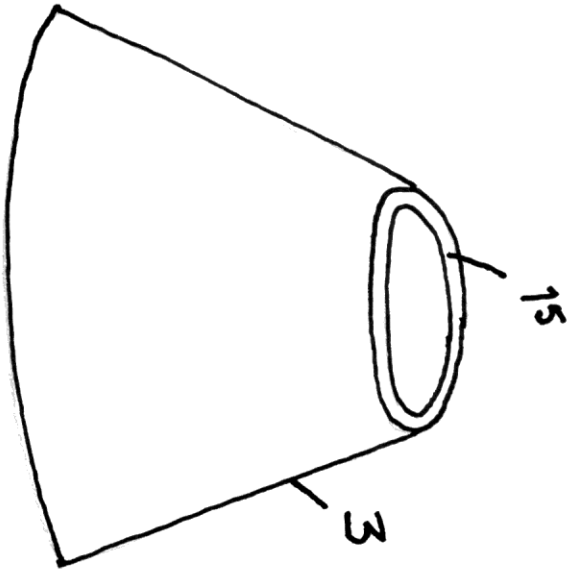

Fig. 8A

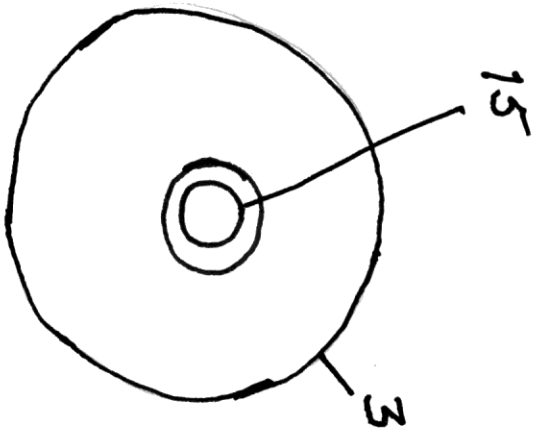

Fig. 8B

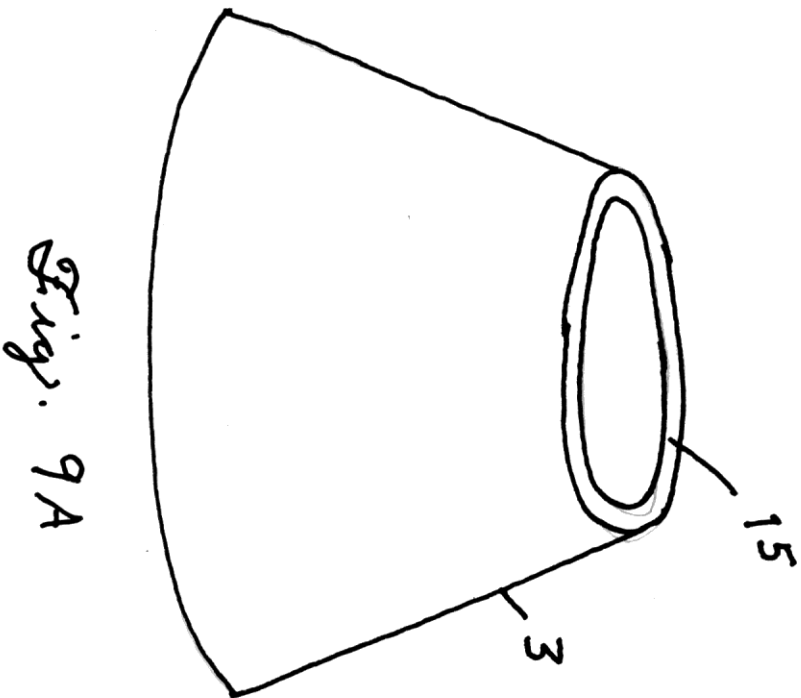

Fig. 9A

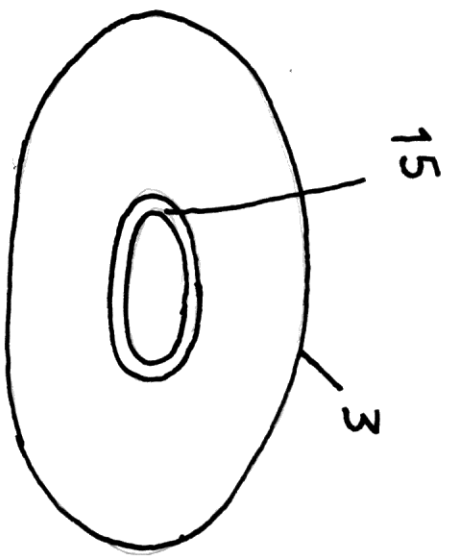
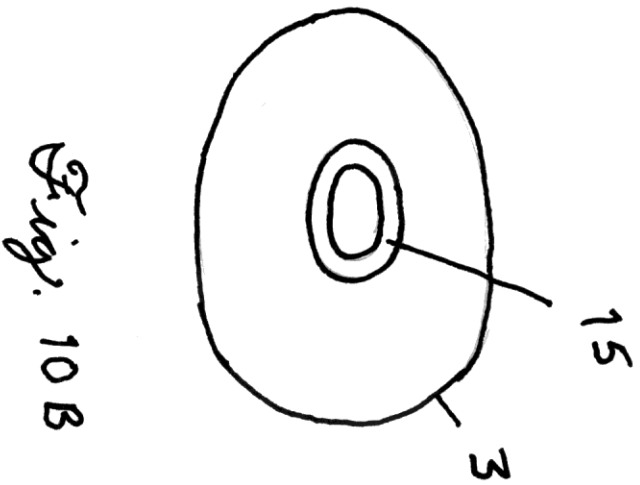
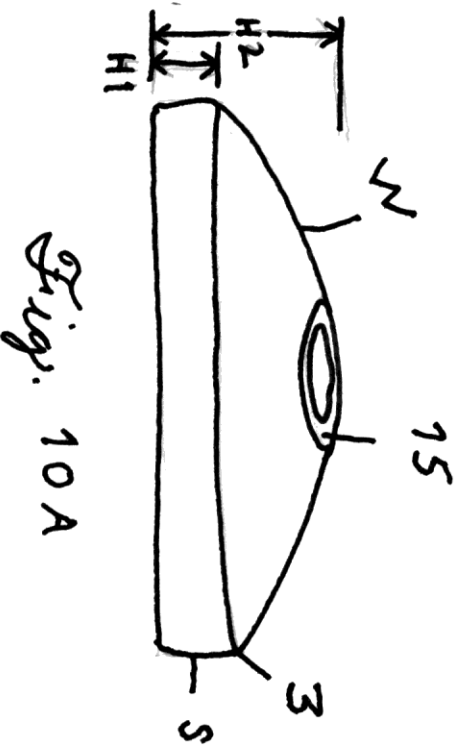

Fig. 9B



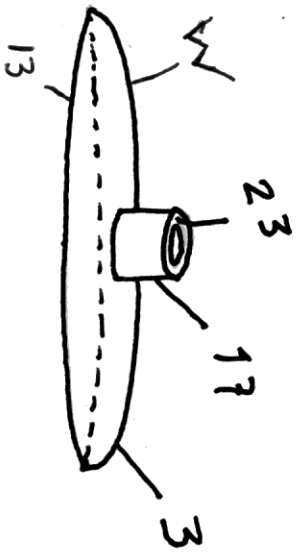

Fig. 11A

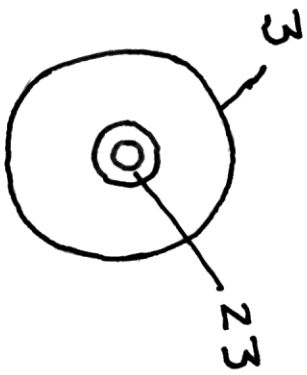

Fig. 11.B

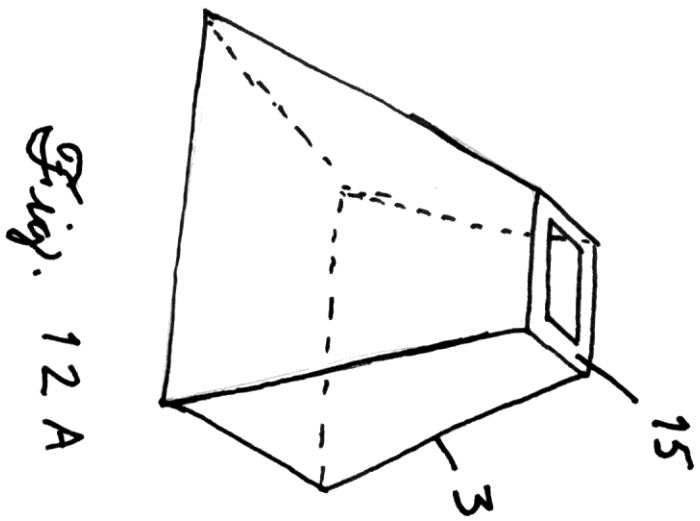

Fig. 12A

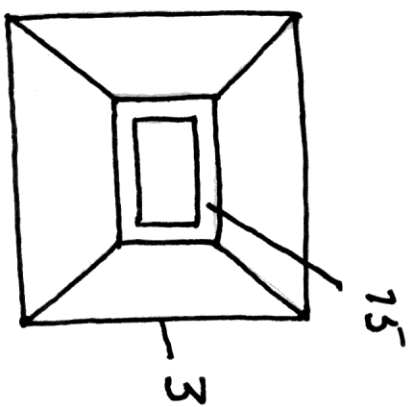

Fig. 12B

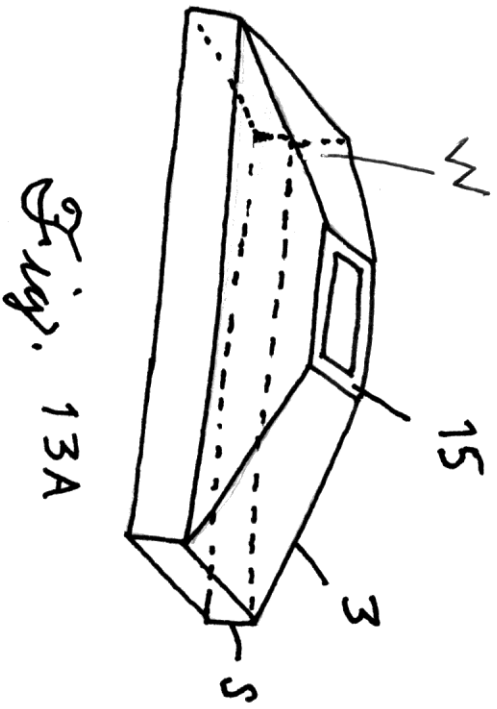

Fig. 13A

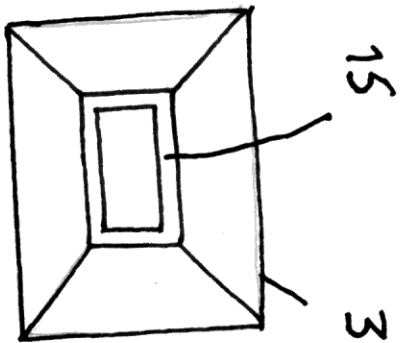

Fig. 13B

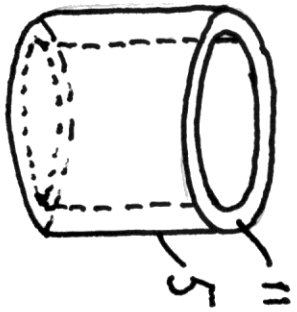

Fig. 14A

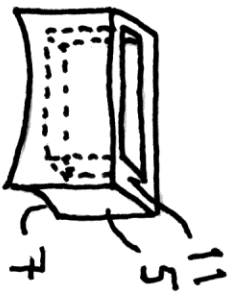

Fig. 15A

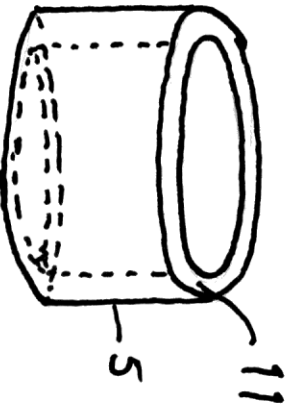

Fig. 16A

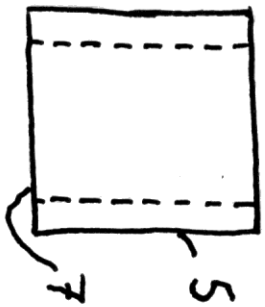

Fig. 14B



Fig. 15B

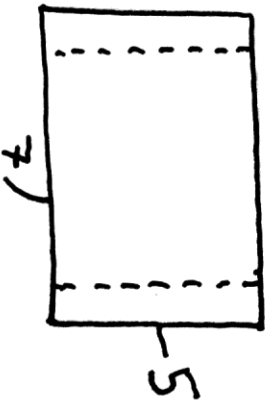

Fig. 16B

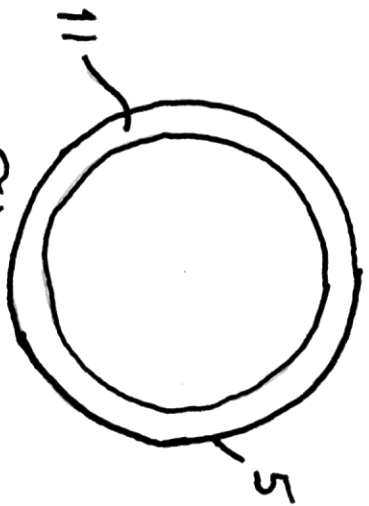

Fig. 14C

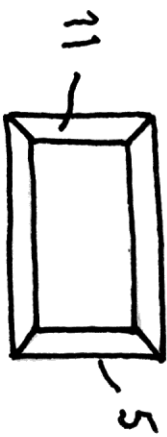

Fig. 15C

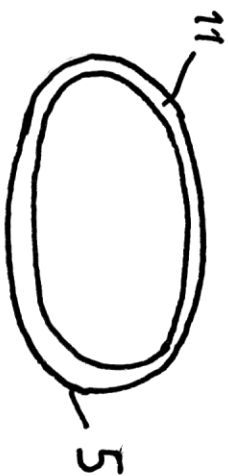

Fig. 16C

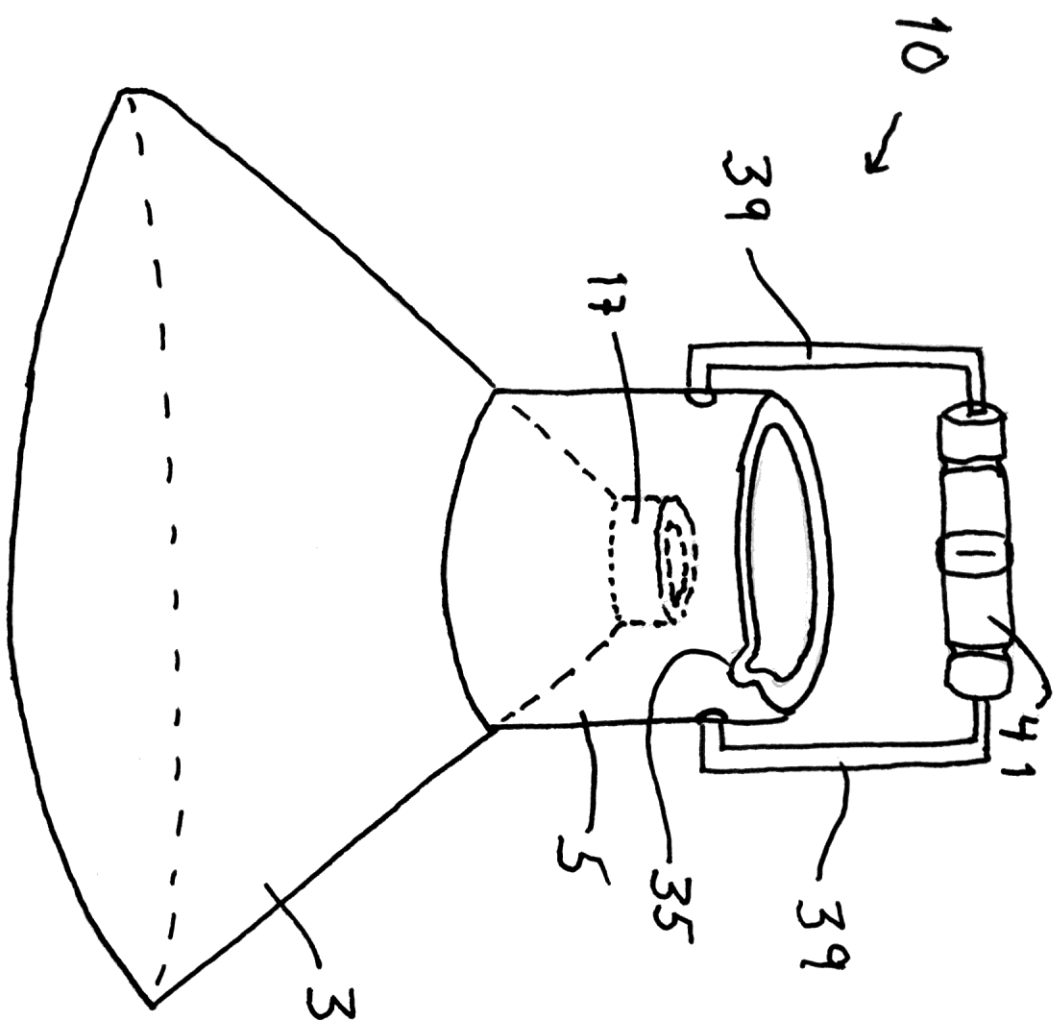

Fig. 17

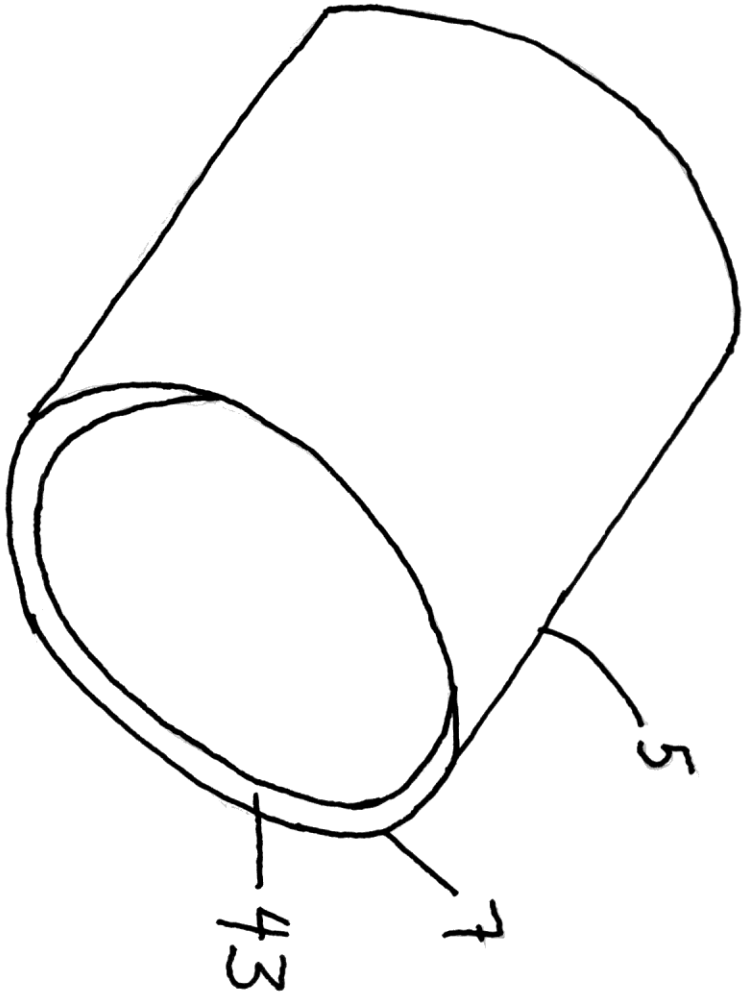

Fig. 18

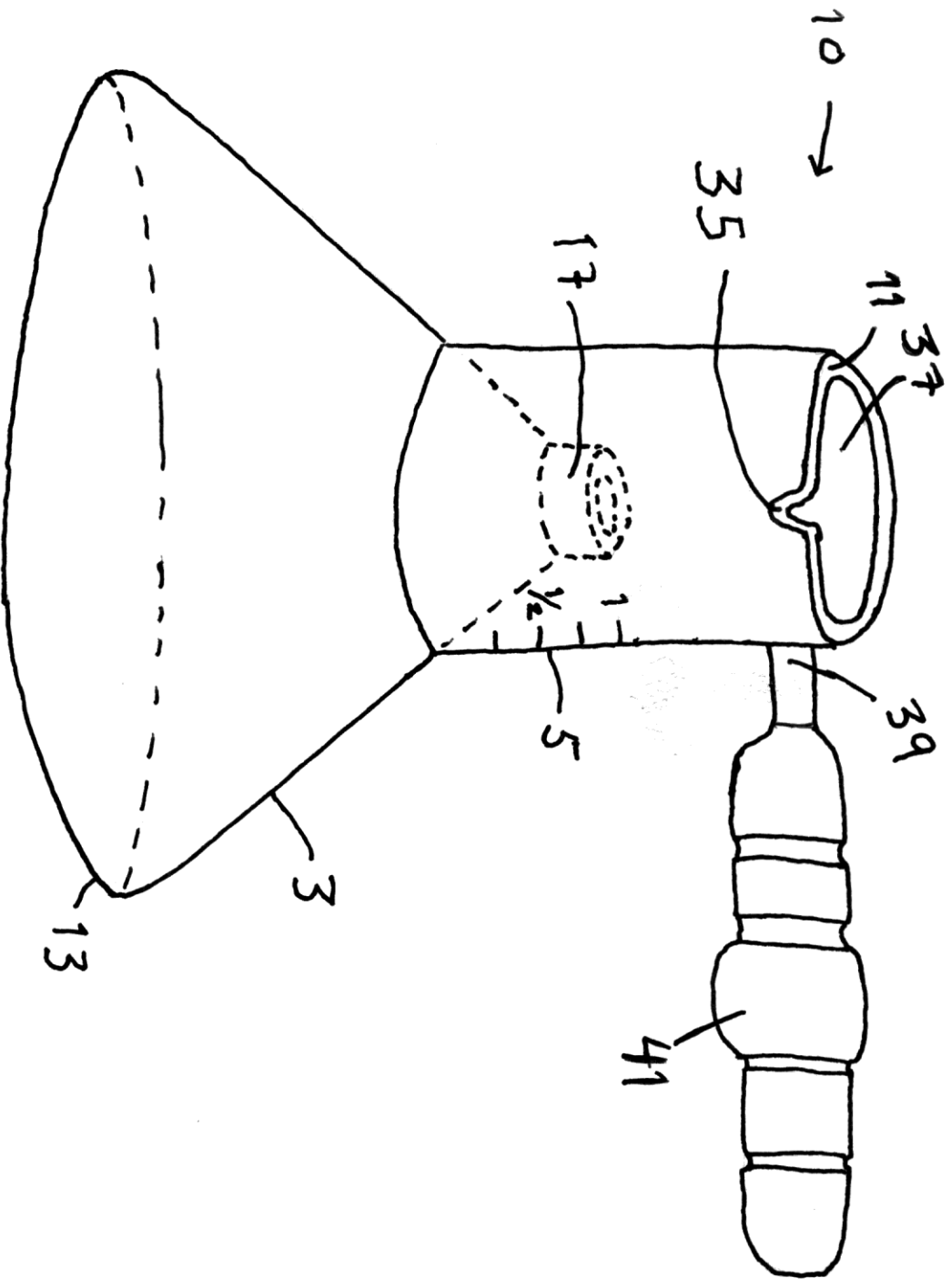

Fig. 19

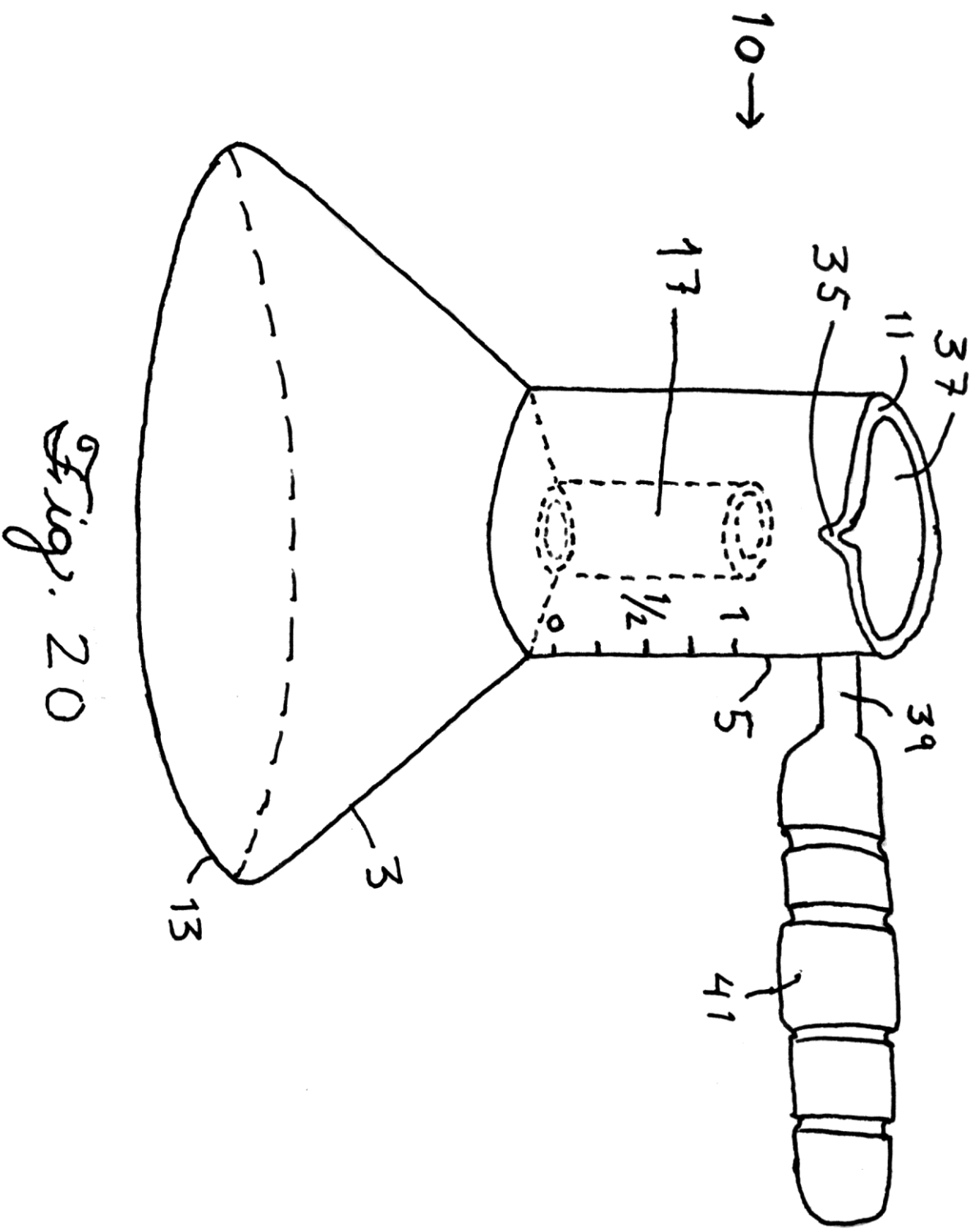

Fig. 20

